



MAKING A DIFFERENCE **FOR THE WORLD OF TOMORROW**

VDL Hydrogen Systems BV | Marius Ponten
15-05-2025



STRENGTH THROUGH COOPERATION

FACTS AND FIGURES

VDL Groep / VDL Hydrogen Systems



Combined revenue
€6,4 billion



Net Result
€82 million



Technology



**Pressurized
Alkaline electrolysers**

Main application

Large scale hydrogen production

Toepassingen voor groene waterstof

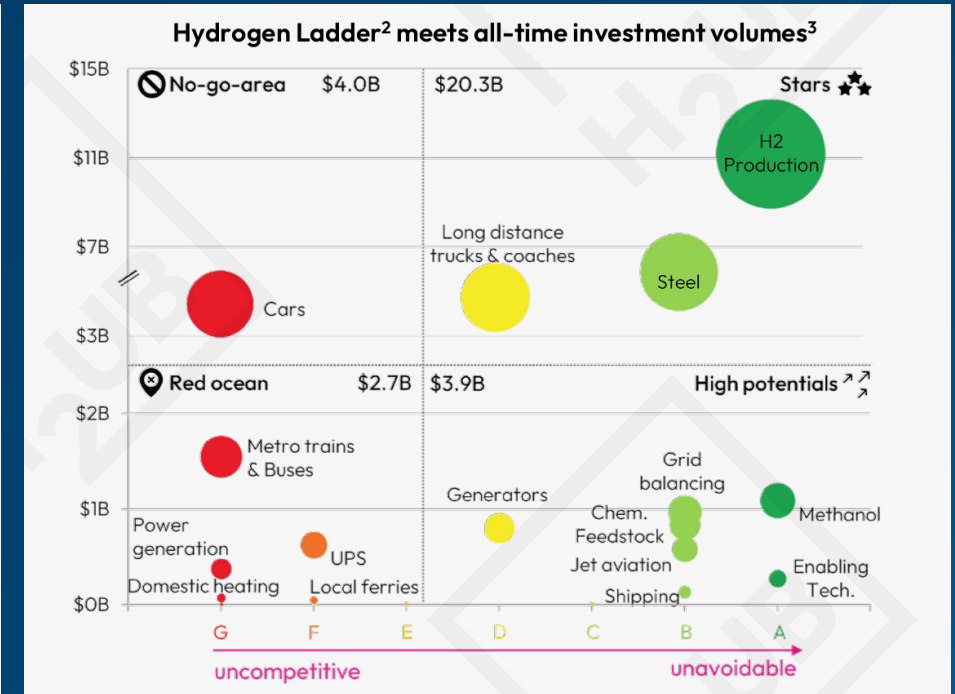
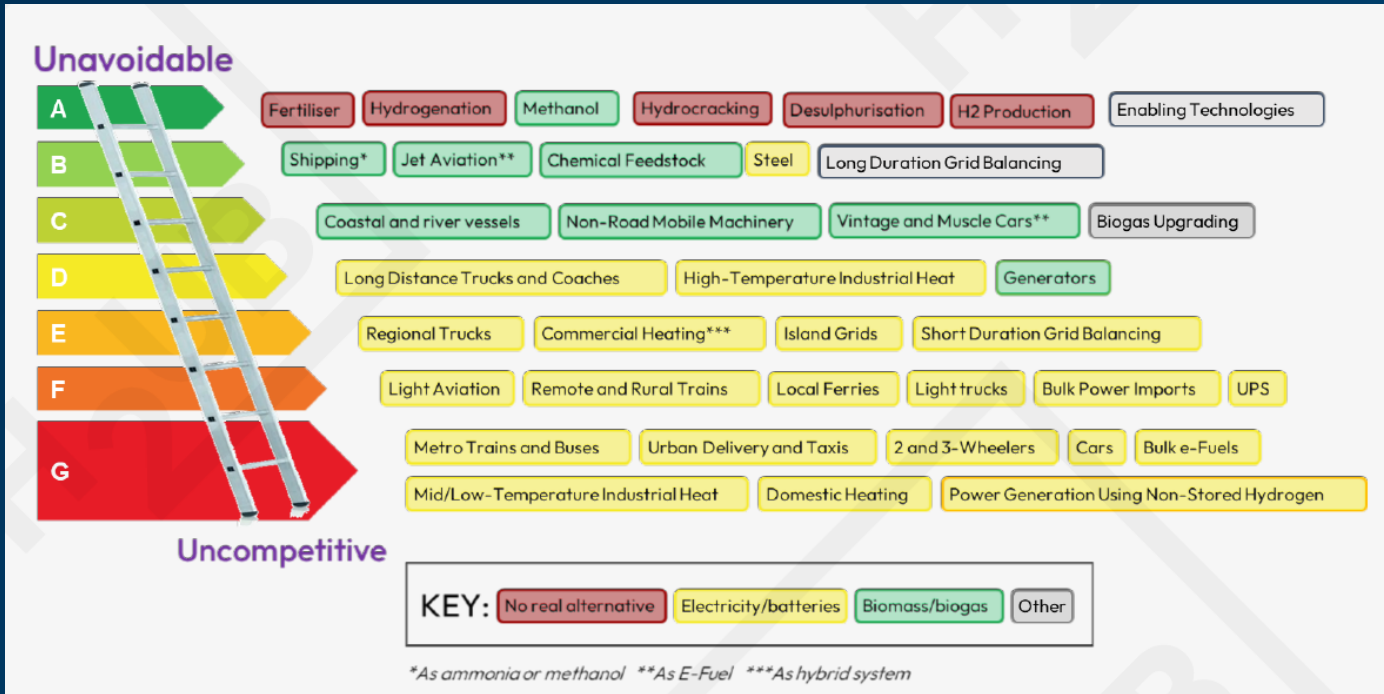

De Nederlandse situatie voor groene waterstof

Huidige kosten voor groene waterstof geproduceerd in Nederland (€8 tot €12) factor 3 a 4 te hoog.

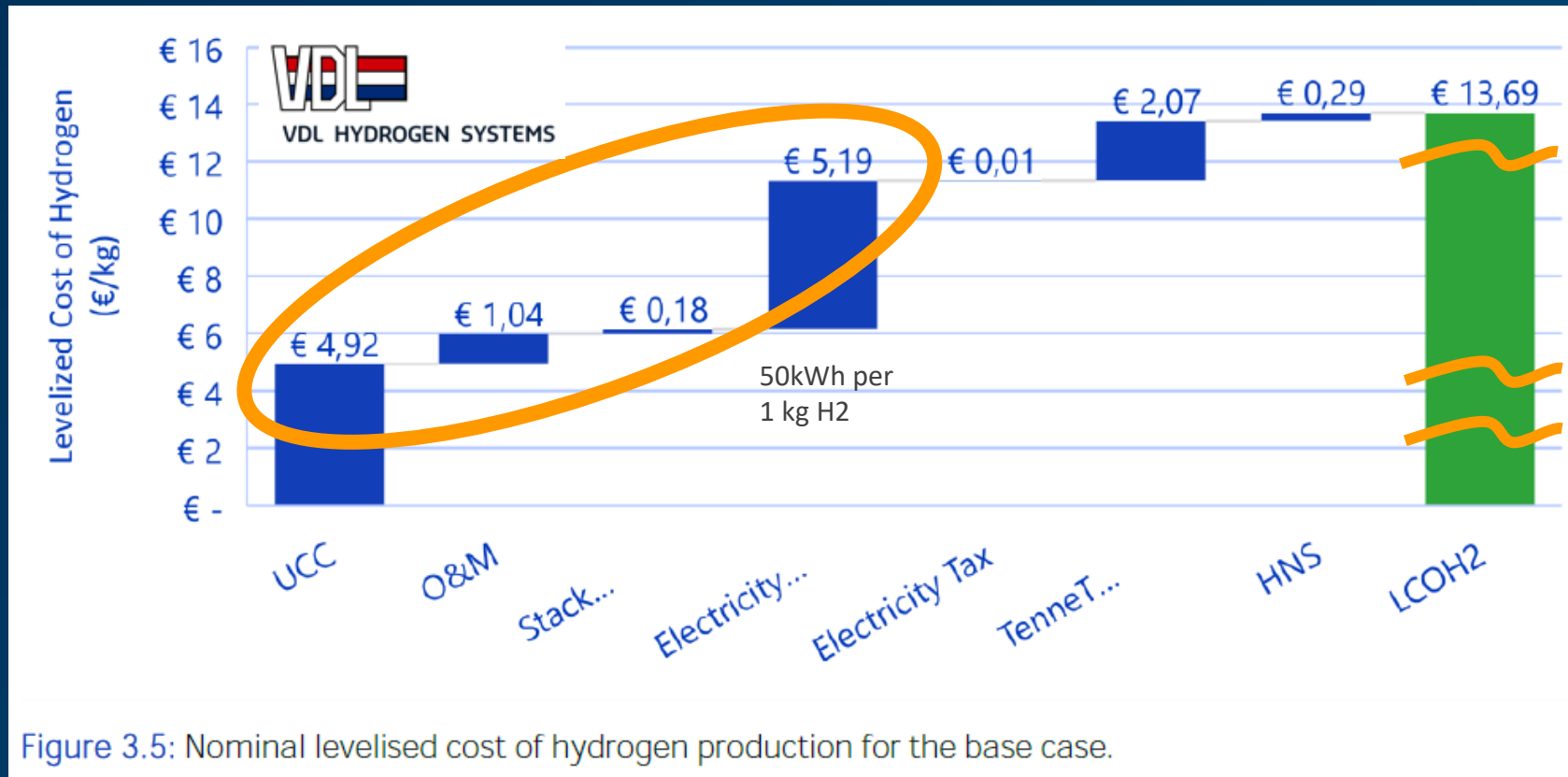
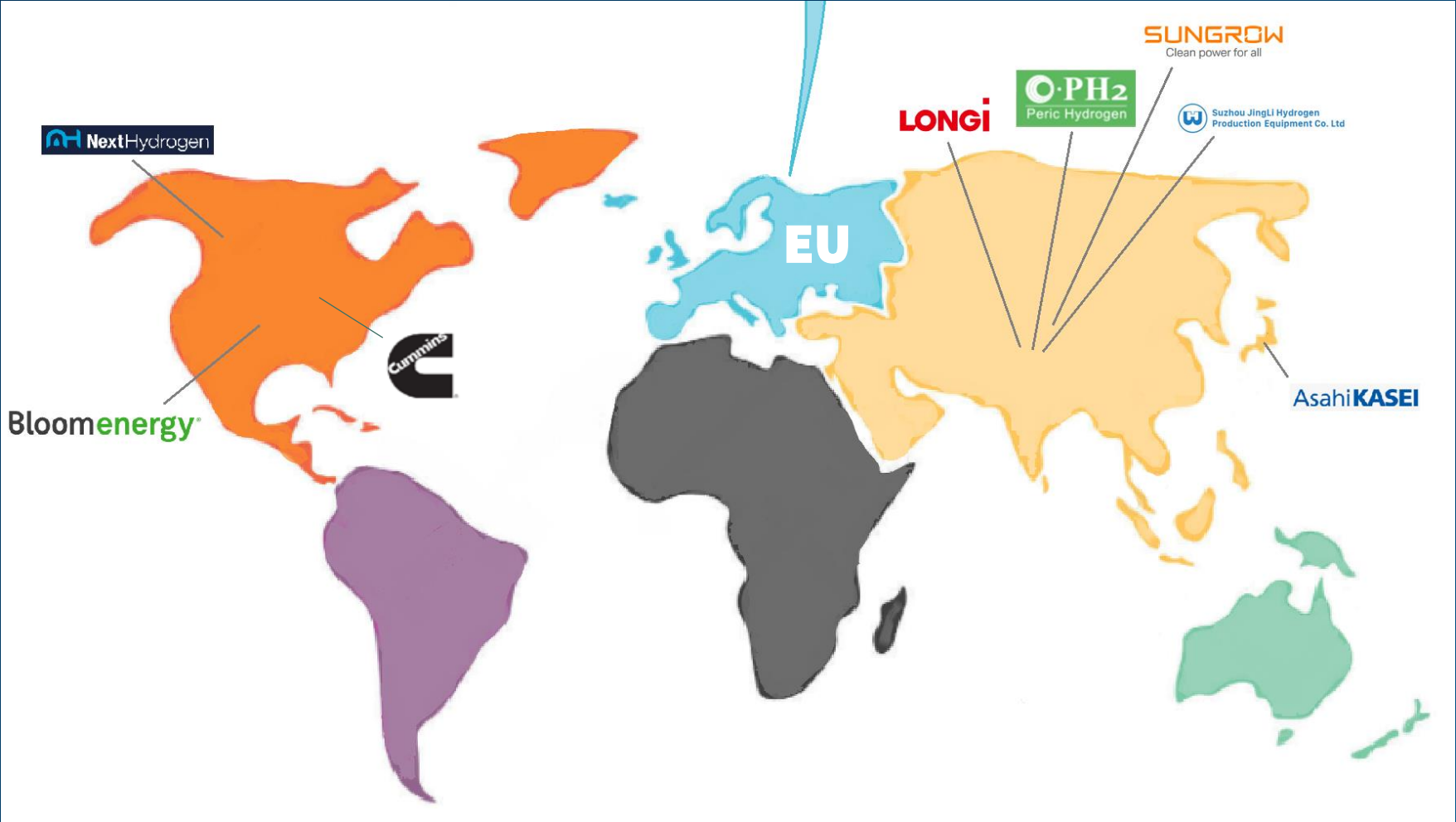

Figure 3.5: Nominal levelised cost of hydrogen production for the base case.

Alkaline leveranciers buiten Europa



Alkaline leveranciers in Europa

Electrolyser maker Green Hydrogen Systems takes big step towards **bankruptcy** after failing to secure new funding

HydrogenPro reports **\$18m loss** for 2024 amid falling revenues and green hydrogen market slowdown

Nel to **receive €135 million** for industrialization of electrolyzer technology



Electrolyser maker John Cockerill Hydrogen used substantial part of €230m funding round to clear **€59m of debts**

Cummins has reported a **\$764m pre-tax loss** for its Accelera unit



Sunfire **Secures €200 Million** Guarantee Financing

Struggling hydrogen electrolyser maker McPhy launches tender **to find buyer** for itself

Stargate Hydrogen **raises 11 million** Euro Series A for scaling up precious metal free electrolyzers

Opbouw van een electrolyser

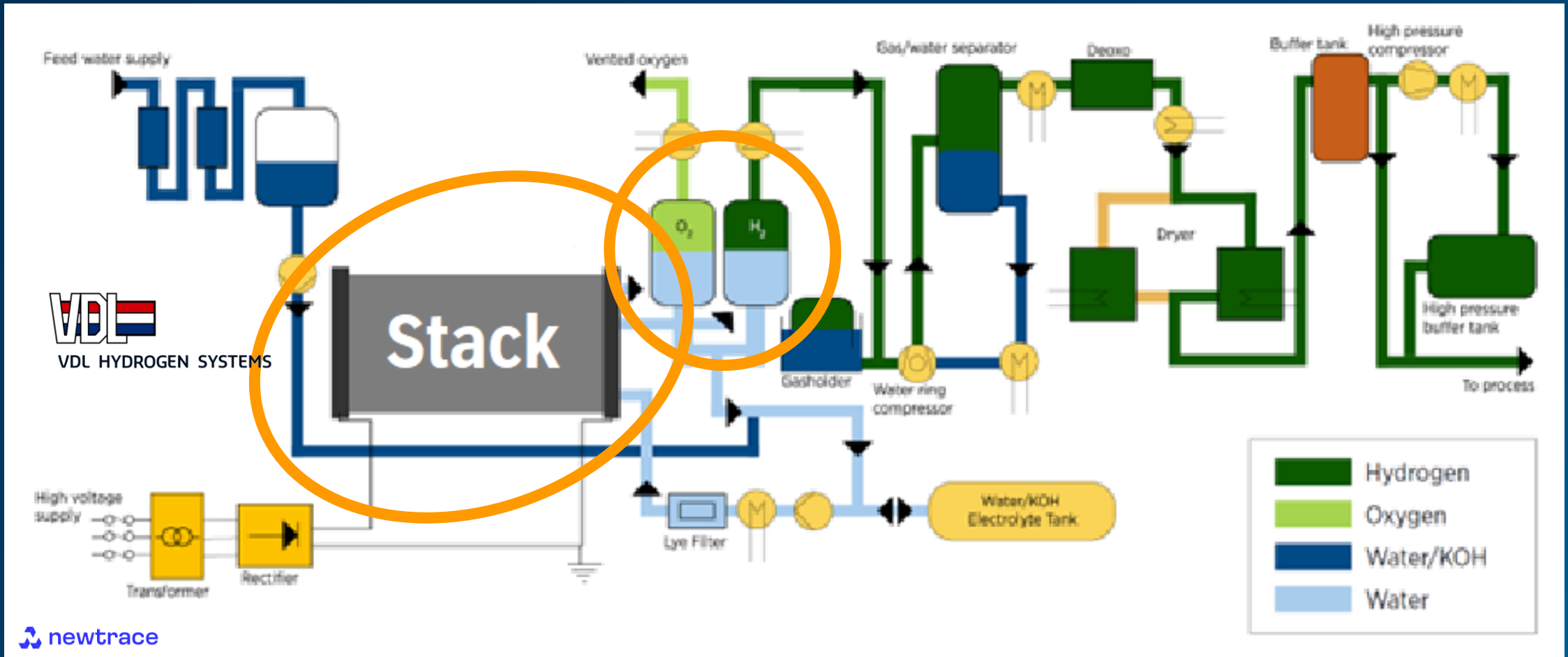



Pressurized alkaline **stacks**



Hydrogen Pro



John Cockerill



Stargate Hydrogen



Green Hydrogen Systems



Sunfire



Nel

VDL Alkaline electrolyser USP's

A 10bar pressurized Alkaline electrolyser

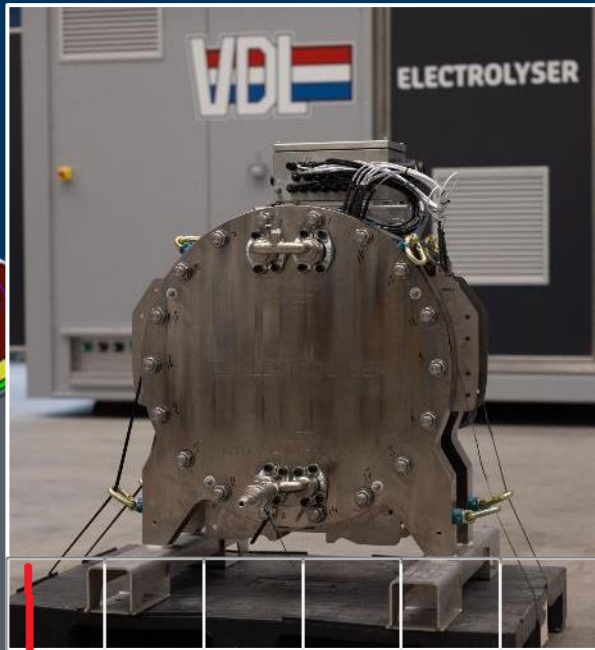

- ✓ Optimised towards lowest **LCOH**
- ✓ **PFAS free design**
- ✓ **Flexible operation**
- ✓ **Small footprint**

Low LCOH due to:
Flexible operation
High efficiency
First pressurizing steps in stack
Low relative BOP cost
High volume production design

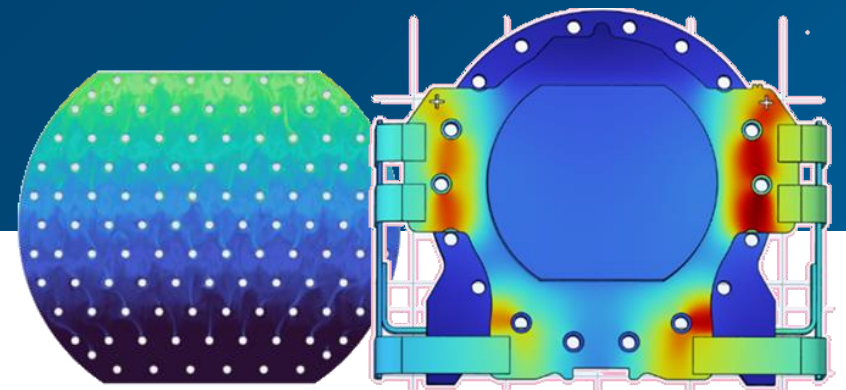
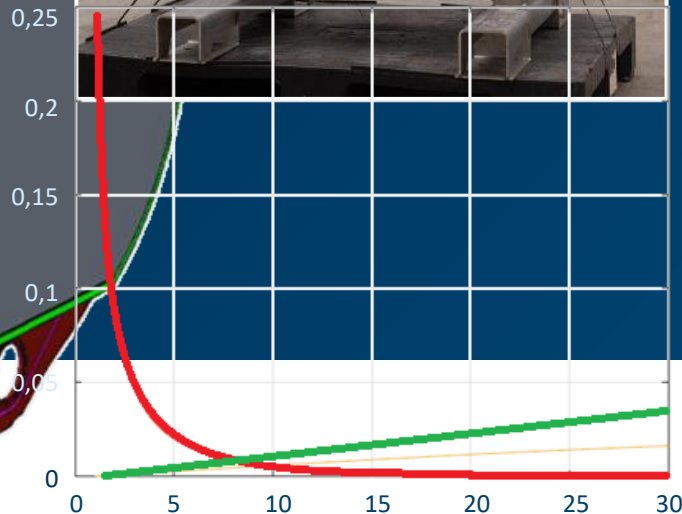
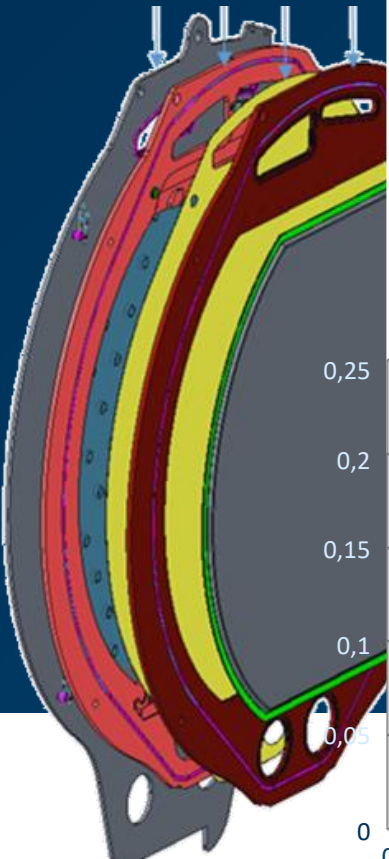

Cost optimized design

5-15 bar results in lower LCOH because of substantially lower overall system compression cost

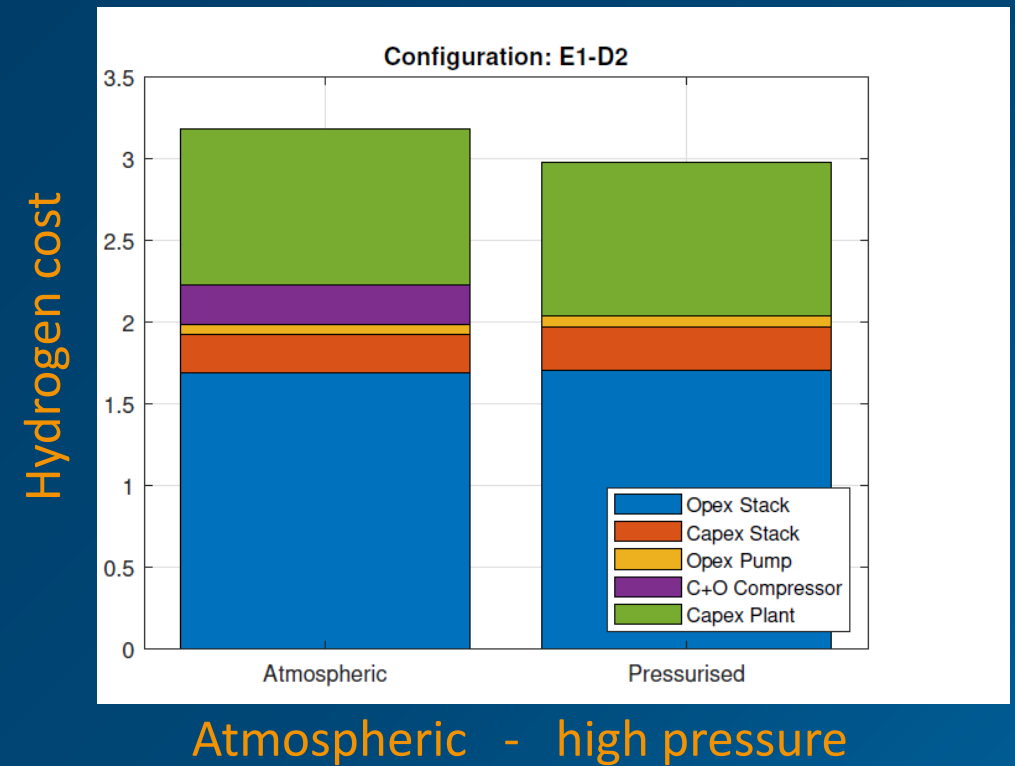
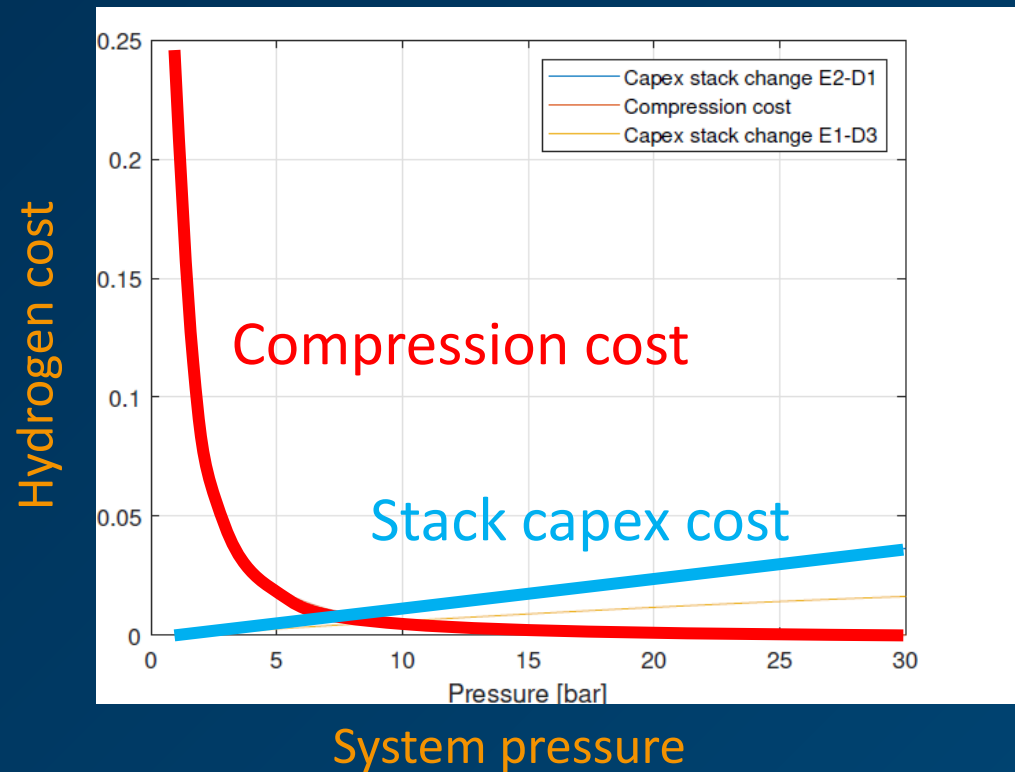

Alkaline roadmap VDL

From prototype, pilot and demonstrator to a GW production factory



Alkaline roadmap VDL

Scale of 50 kW -> 500kW -> 15MW

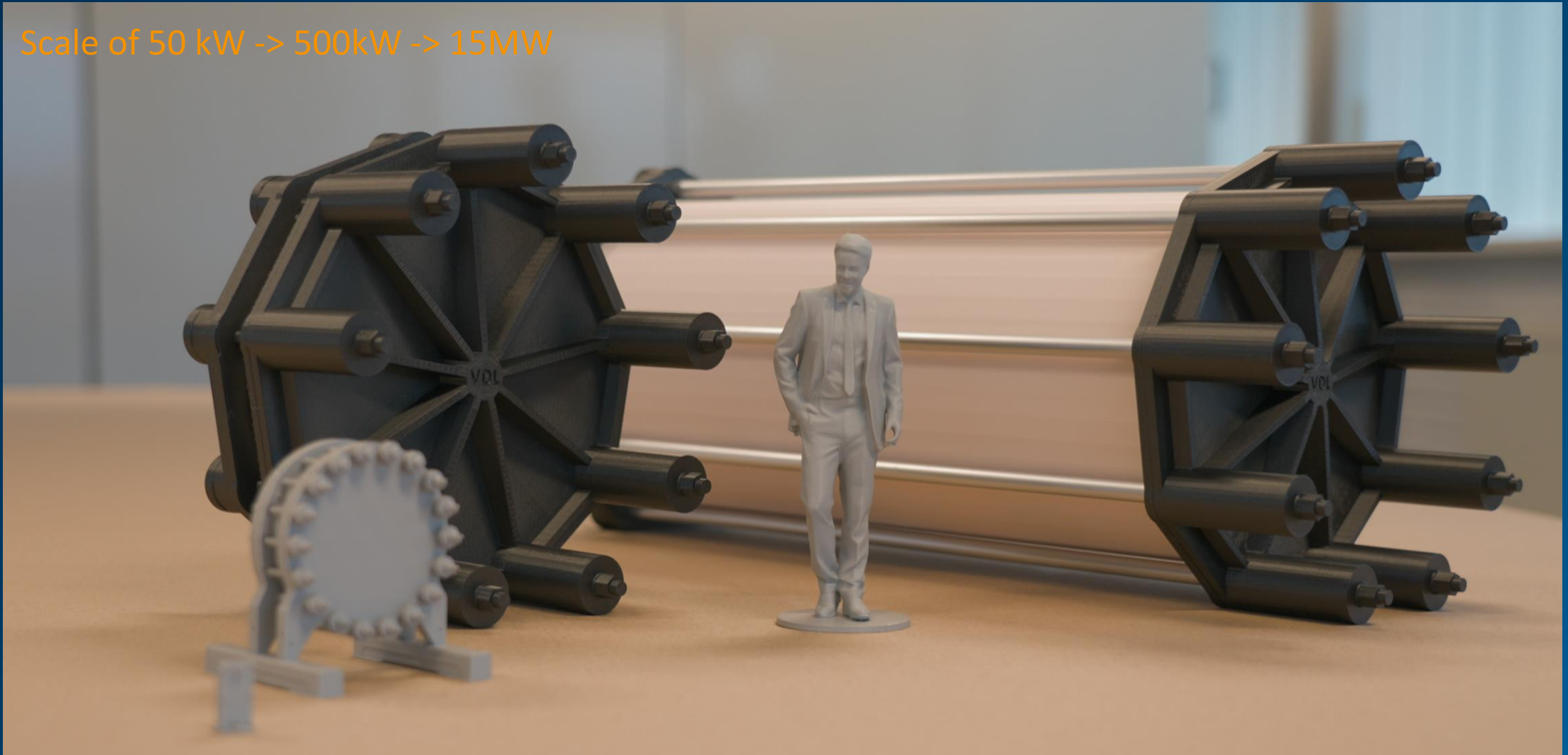

Alkaline test setup

50kW shortstack | 10 bar | 1,2A/cm²

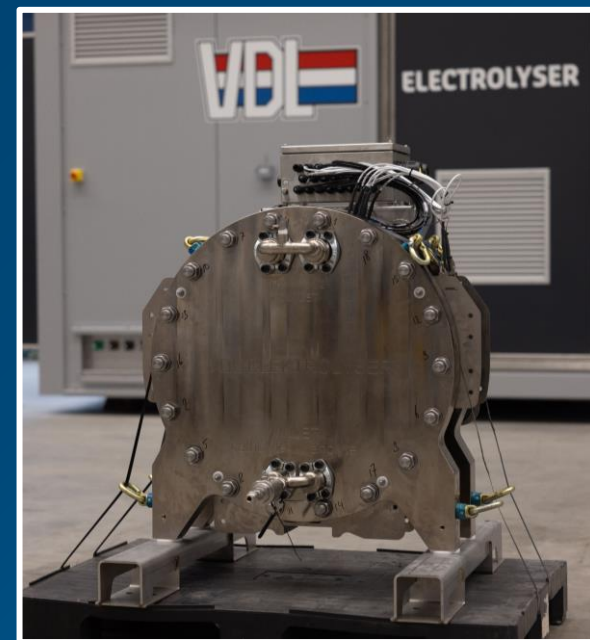
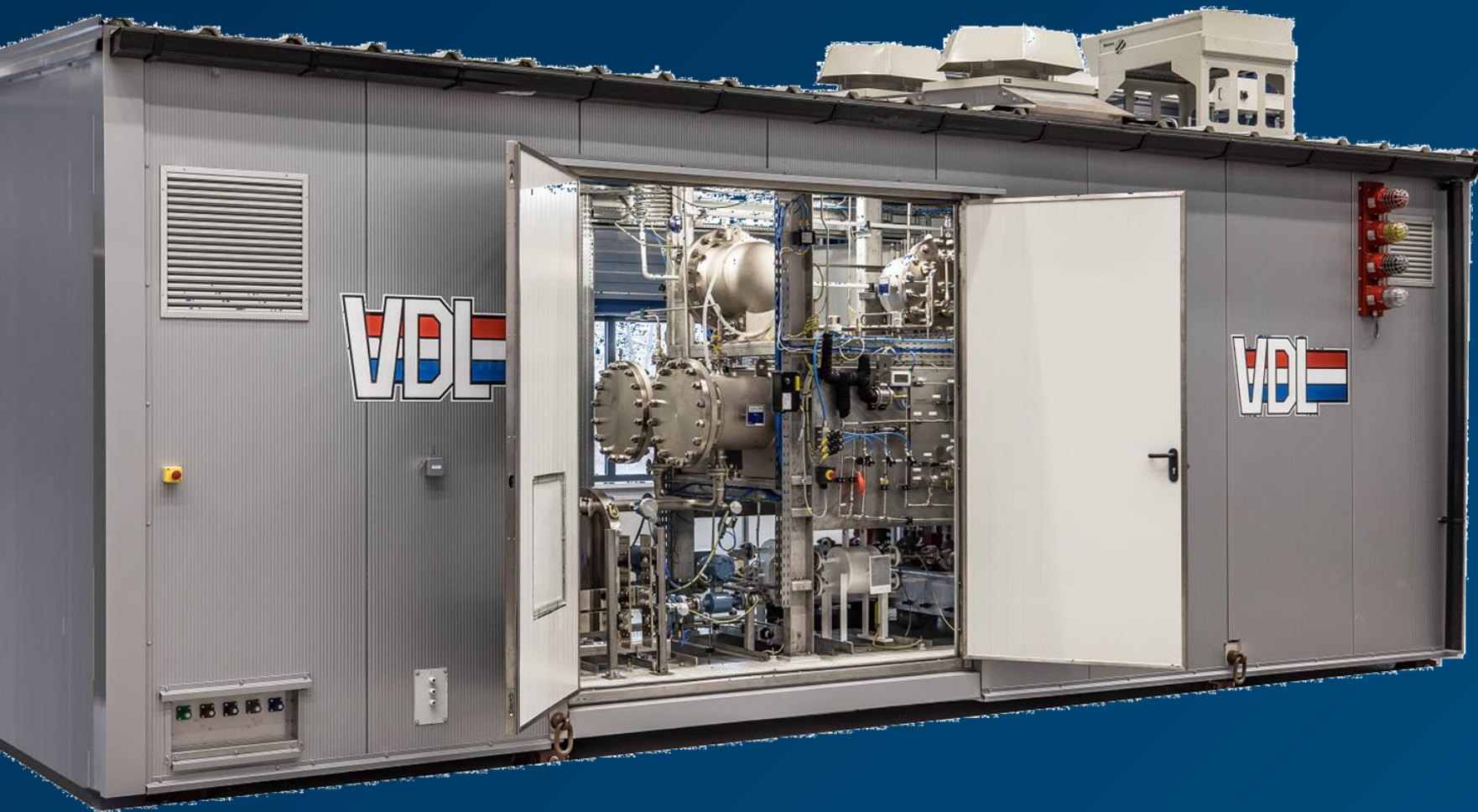



MAKING A DIFFERENCE **FOR THE WORLD OF TOMORROW**

Marius Ponten | m.ponten@vdl.nl | +31 (0)6 21 89 11 90



STRENGTH THROUGH COOPERATION